

Passive Converter

AD-TW 501 ST

Description

The passive converter AD-TW 501 ST converts an impressed signal of 0-20 mA into a linear voltage signal of 0-10 V. The output signal is from the input isolated galvanically and does not reflect back to the input signal.

The passive converter does not need any auxiliary power, the low energy which is required is taken from the input signal.

Application

Economical galvanical isolation at simultaneous signal conversion without auxiliary power.

Specialities

- no auxiliary power, therefore no influence on the mains
- high linear normsignal conversion with galvanical isolation
- no heat evolution, as no auxiliary power required
- facile to employ plug-in technic on terminal blocks
- compatibility to connect with further passive converters

Technical data

Power supply:	not necessary !!
Input:	0-20 mA
Input voltage drop:	approx. 1,7 V
Operate current:	ca. 80 μ A
Output:	0-10 V
Output load:	min 50 kOhm
Linearity:	< 0,3 %
Reaction time:	10-90 % = < 40 ms 90-10 % = < 20 ms
Isolation test voltage:	Input/Output: 1,5 kV RMS
Ambient temperature:	0 to +50 C
Further electronic protection measures	
Input:	protection of confusing the poles, overvoltage protection
Output:	short-circuit-proof



Connection and dimension: AD-TW 501 ST



weight: ca. 150 g
protection: IP 30
manner of fastening:
DIN rail 35mm (EN50022)

connection data:
fine-wire: 2,5 mm²
single-wire: 4,0 mm²

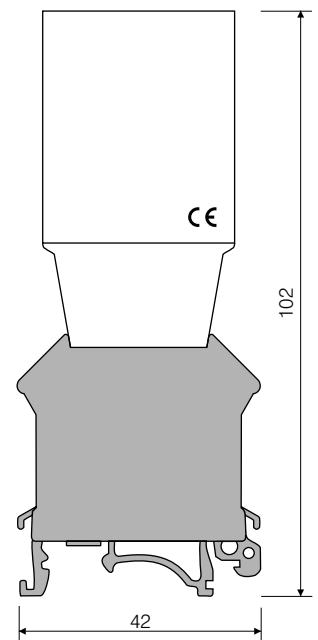
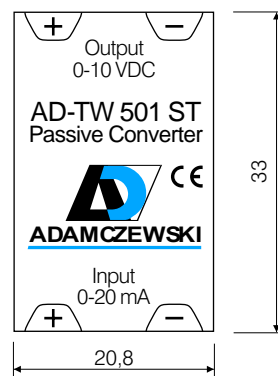

Printed 01/1999. We reserve the right for technical changes



ADAMCZEWSKI
Elektronische Messtechnik GmbH

Felix-Wankel-Str. 13
Tel. +49 (0)7046-875
vertrieb@ad-messtechnik.de

74374 Zaberfeld
Fax +49 (0)7046-7678
www.adamczewski.com